

Waterproof Power Box



- Aluminum Alloy and SECC Steel Construction
- IP66 Ingress Rating
- Compatible with PTZ and IPC Cameras
- Supports Multiple Types of Power Sources
- Compatible with 1A404XBNR, 40212TNI, 49425XBNR, 6AL445XANR, 5A445XANR, 59232ICLA and 50432GBNR

Technical Specifications

Construction

Material	Aluminum Alloy and SECC
Product Dimensions (L x W x H)	297.2 mm × 248.0 mm × 130.7 mm (11.70 in. × 9.76 in. × 5.15 in.)
Package Dimensions (L x W x H)	366.0 mm × 298.0 mm × 183.0 mm (14.41 in. × 11.73 in. × 7.20 in.)
Net Weight	3.38 kg (7.45 lb)
Gross Weight	3.86 kg (8.51 lb)
Load Bearing Capacity	8.0 kg (17.64 lb)
Installation	Wall, Pole, or Corner Mount
Screw Thread Type	G1/2

Environmental

Protection Rating	IP66
Operating Temperature	-40 °C to +60 °C (-40 °F to +140 °F)
Operating Humidity	Wall, Pole, or Corner Mount
Storage Temperature	-40 °C to +60 °C (-40 °F to +140 °F)
Storage Humidity	10% to 90% (RH)
Anti-corrosion Level	Basic Protection

Ordering Information

Type	Part Number	Description
Accessory	DH-PFA6400S	Waterproof Power Box

Package Contents

- 1 x Power Box
- 4 x M6 x 25 Screw
- 4 x M6 x 14 Screw
- 4 x M8 Plastic Anchor
- 1 x S5.0 Wrench
- 3 x Water Joint
- 1 x Silicone Plug
- 5 x Cable Tie
- 1 x Installation Guide

Installation

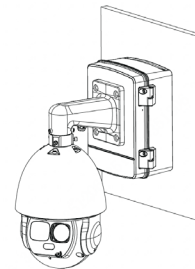

Dimensions

mm [in.]

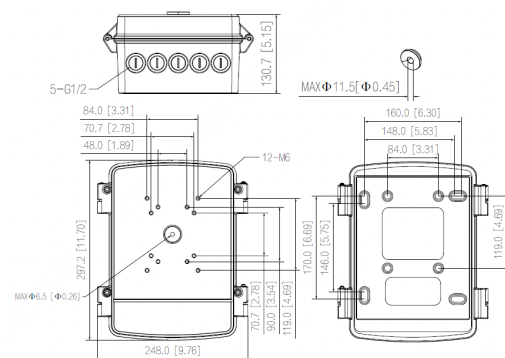

For all possible accessory combinations for this camera, please scan or click the QR code below to go to our accessory selector.

